

# SSC-301-X SPECIFICATIONS

## LARGE WALL HANDSET TELEPHONE FOR RING-DOWN OPERATION

*Standard Analog Power, but also available in VoIP versions*

Vandal resistant stainless steel wall mount telephone for ring-down operation. The telephone will accept incoming calls and relies on external equipment to control calling. Equipped with marine quality chrome mechanical hookswitch, instruction or advertising window, ID window, 32" hearing aid compatible armored cord handset with internal steel lanyard, which is anchored into housing for added strength, tamper resistant security screws, and mounting backplate.



### SPECIFICATIONS

<b>Panel Size:</b>	7.5" W x 21" H x 4.10" D 6.5" D With handset on Hook
<b>Weight:</b>	Approximately 16 lbs.
<b>Mounting Instructions:</b>	<b>Vertical Surface Mount:</b> Separate the cover assembly from the backplate. The backplate assembly is designed to be mounted on any flat vertical surface. Four mounting holes are provided.
<b>Environment:</b>	Temperature: -30°C (-22°F) to 60°C (140°F) Humidity: 0%-90% non-condensating
<b>Input Power:</b>	Telephone Line Powered
<b>Loop Current:</b>	23mA min to 80mA max
<b>Impedance:</b>	600 ohms
<b>Type Jack:</b>	RJ11C
<b>Ringer Equivalency:</b>	0.4A
<b>Hearing Aid Compatible:</b>	Meets EIA standards
<b>UL &amp; FCC Registration:</b>	Certified
<b>ACCESSORIES:</b>	301-037 Security Tool (required for installation)

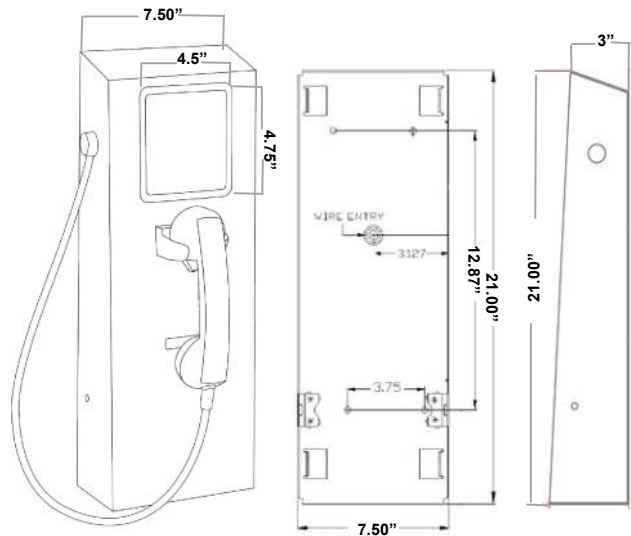

### ADDITIONAL OPTIONS

IP - Voice over Internet Protocol Version available on all models (SIP)

-M	-IVC	-ACH**	-ACH*	-CCH*	-RIL	-RIS
<b>Sealed Magnetic Hookswitch</b> • Completely Sealed • No Moving Parts	<b>Push Button Volume Control</b> • Background Noise reducer	Other Length armored cord from 12" to 72"(inches). Example: <b>-ACH12</b> 12" Long	<b>ACHW-White Handset</b> <b>ACHR-Red Handset</b> (Black is standard)	Coiled cord available from 5', 10', & 15' (feet). Example: <b>-CCH5</b> 5' Long	Ring Indicator Light located on the phone panel for visual ring indication	Ring Indicator Flashing Blue Light (Requires AC Power)



*Providing Telecommunication Solutions Since 1930*

Communication Equipment  
& Engineering Company

<http://www.ceeco.net>  
Email: [sales@ceeco.net](mailto:sales@ceeco.net)

519 SW Park Street  
Okeechobee, FL

Voice 863-357-0798  
Fax 863-357-0006